



Ultrasonic sensor

UB800-18GM40A-U-V1-Y70111842

- Short design, 40 mm
- Function indicators visible from all directions
- Analog output 0 ... 10 V
- Measuring window adjustable
- Program input
- Temperature compensation
- Supplied with mounting accessory

Single head system

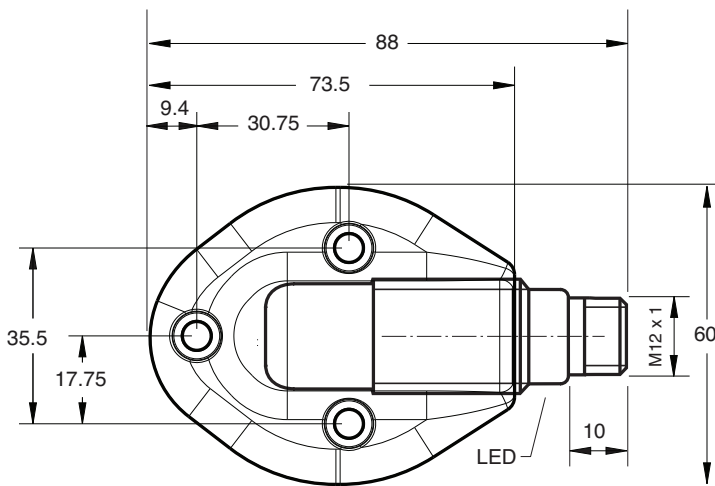

Technical Data

General specifications

Sensing range	50 ... 800 mm
Adjustment range	70 ... 800 mm
Dead band	0 ... 50 mm
Standard target plate	100 mm x 100 mm
Transducer frequency	approx. 255 kHz
Response delay	approx. 100 ms

Indicators/operating means

LED green	Power on
LED yellow	solid yellow: object in the evaluation range yellow, flashing: program function, object detected
LED red	solid red: Error red, flashing: program function, object not detected

Electrical specifications

Operating voltage	U_B	15 ... 30 V DC , ripple 10 % _{SS}
No-load supply current	I_0	≤ 20 mA

Input

Input type	1 program input lower evaluation limit A1: $-U_B ... +1 V$, upper evaluation limit A2: $+4 V ... +U_B$ input impedance: > 4.7 kΩ, pulse duration: ≥ 1 s
------------	--

Output

Release date: 2021-07-16 Date of issue: 2021-07-16 Filename: 70111842_eng.pdf

Refer to "General Notes Relating to Pepperl+Fuchs Product Information".

Pepperl+Fuchs Group
www.pepperl-fuchs.com

USA: +1 330 486 0001
fa-info@us.pepperl-fuchs.com

Germany: +49 621 776 1111
fa-info@de.pepperl-fuchs.com

Singapore: +65 6779 9091
fa-info@sg.pepperl-fuchs.com

PEPPERL+FUCHS

Technical Data

Output type	1 analog output 0 ... 10 V
Default setting	evaluation limit A1: 70 mm evaluation limit A2: 800 mm
Resolution	0.4 mm at max. sensing range
Deviation of the characteristic curve	± 1 % of full-scale value
Repeat accuracy	± 0.5 % of full-scale value
Load impedance	> 1 kOhm
Temperature influence	± 1.5 % of full-scale value
Compliance with standards and directives	
Standard conformity	
Standards	EN 60947-5-2:2007+A1:2012 IEC 60947-5-2:2007 + A1:2012 EN 60947-5-7:2003 IEC 60947-5-7:2003
Ambient conditions	
Ambient temperature	-25 ... 70 °C (-13 ... 158 °F)
Storage temperature	-40 ... 85 °C (-40 ... 185 °F)
Mechanical specifications	
Connection type	Connector plug M12 x 1 , 4-pin
Degree of protection	IP67
Material	
Housing	brass, nickel-plated
Transducer	epoxy resin/hollow glass sphere mixture; foam polyurethane, cover PBT
General information	
Note	Sensor is installed in mounting flange MH-18GMA

Connection

Standard symbol/Connections:
(version U)

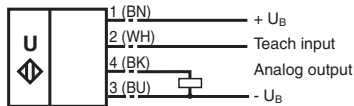

Core colors in accordance with EN 60947-5-2.

Connection Assignment

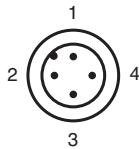

Wire colors in accordance with EN 60947-5-2

1	BN	(brown)
2	WH	(white)
3	BU	(blue)
4	BK	(black)

Characteristic Curve

Characteristic response curve

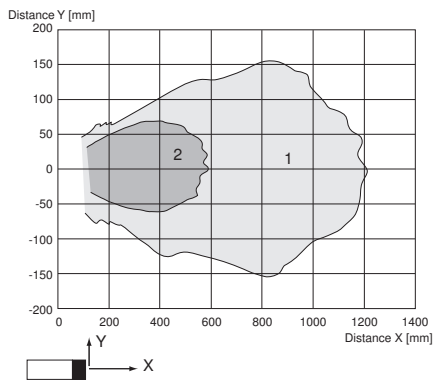

Curve 1: flat surface 100 mm x 100 mm
Curve 2: round bar, Ø 25 mm

Programming

Programming the analog output mode

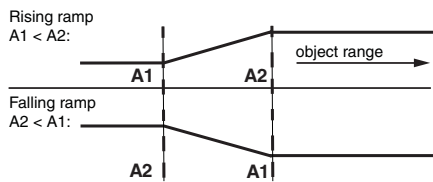

A1 -> ∞, A2 -> ∞: Detection of object presence

Object detected: 10 V
No object detected: 0 V

Accessories

	V1-W-2M-PUR	Female cordset single-ended M12 angled A-coded, 4-pin, PUR cable grey
	MH-18GMA	Mounting flange for 18 mm diameter, right-angle ultrasonic sensors
	V1-G-2M-PUR	Female cordset single-ended M12 straight A-coded, 4-pin, PUR cable grey

Release date: 2021-07-16 Date of issue: 2021-07-16 Filename: 70111842_eng.pdf

Programming

Adjusting the evaluation limits

The ultrasonic sensor features an analogue output with two teachable evaluation limits. These are set by applying the supply voltage $-U_B$ or $+U_B$ to the TEACH-IN input. The supply voltage must be applied to the TEACH-IN input for at least 1 s. LEDs indicate whether the sensor has recognised the target during the TEACH-IN procedure. The lower evaluation limit A1 is taught with $-U_B$, A2 with $+U_B$.

Two different output functions can be set:

1. Analogue value increases with rising distance to object (rising ramp)
2. Analogue value falls with rising distance to object (falling ramp)

TEACH-IN rising ramp (A2 > A1)

- Position object at lower evaluation limit
- TEACH-IN lower limit A1 with $-U_B$
- Position object at upper evaluation limit
- TEACH-IN upper limit A2 with $+U_B$

TEACH-IN falling ramp (A1 > A2):

- Position object at lower evaluation limit
- TEACH-IN lower limit A2 with $+U_B$
- Position object at upper evaluation limit
- TEACH-IN upper limit A1 with $-U_B$

Default setting

A1: unusable area
 A2: nominal sensing range
 Mode of operation: rising ramp

LED Displays

Displays in dependence on operating mode	Red LED	Yellow LED
TEACH-IN evaluation limit		
Object detected	off	flashes
No object detected	flashes	off
Object uncertain (TEACH-IN invalid)	on	off
Normal mode (evaluation range)	off	on
Fault	on	previous state

Release date: 2021-07-16 Date of issue: 2021-07-16 Filename: 70111842_eng.pdf